



PRODUCT CATALOGUE



SCREENBEE SB 15.44H

Mobile, compact, hook lift trommel screen

1500 mm dia. / 4300 mm

Folding conveyors

Digital control system
via an integrated 7" colour
HMI display

Hybrid/electric/Built-in
aggregate Pramac GBW 15Y
and Pramac GBW 22Y
Yanmar engine Tier 6



Hook Lift System

Wireless Remote Control
supplied by Tele Radio* optional

SCREENBEE SB 15.44H

Mobile, compact, hook lift trommel screen

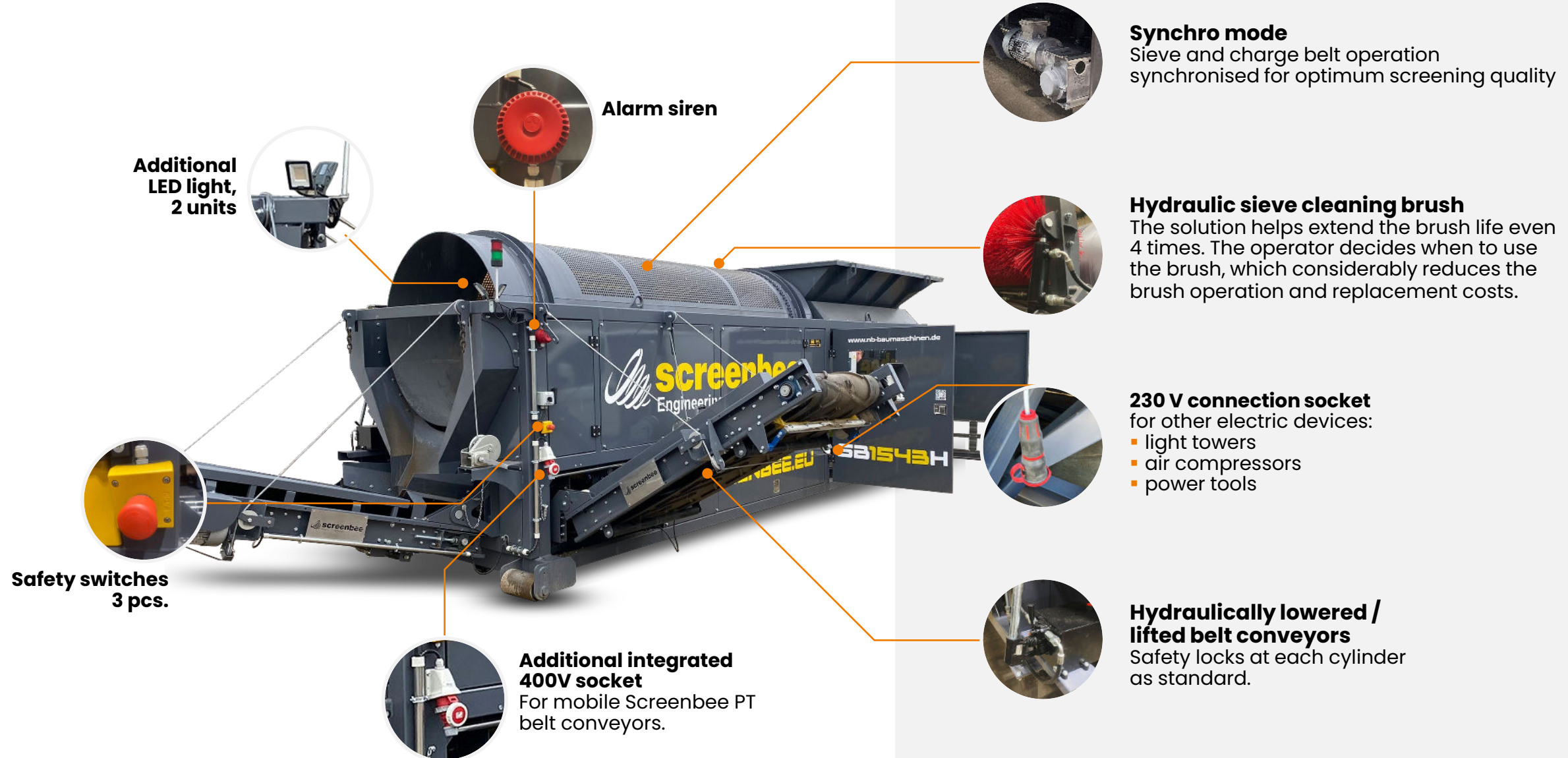

Additional LED light, 2 units

Alarm siren

Synchro mode

Sieve and charge belt operation synchronised for optimum screening quality

Hydraulic sieve cleaning brush

The solution helps extend the brush life even 4 times. The operator decides when to use the brush, which considerably reduces the brush operation and replacement costs.

230 V connection socket

for other electric devices:

- light towers
- air compressors
- power tools

Hydraulically lowered / lifted belt conveyors

Safety locks at each cylinder as standard.

Safety switches 3 pcs.

Additional integrated 400V socket

For mobile Screenbee PT belt conveyors.

SCREENBEE SB 15.44H

Mobile, compact, hook lift trommel screen

DIMENSIONS AND WEIGHT

- Length (working): 9300 mm
- Width (working): 4200 mm
- Length (transport): 7960 mm
- Width (transport): 2450 mm
- Height (transport): 3100 mm
- Weight: 7500 kg

CAPACITIES

- Diesel tank capacity: 51L / Genset
- Capacity – Feeder: 3.7 cum

SCREEN DRUM

- Drum size: 1500 mm Dia. X 4300 mm
- Drum system: Chain drive via 200 dia. support wheels
Drive system: – NORD 3.0 KW SK9022.1
- Speed adjustable: Including
- Screen Operating Speed Range: 0 to 17 RPM
- Hydraulic Cleaning Brush: Including

POWER UNIT

- ELECTRIC/HYBRID Power supply
- Genset: Pramac GBW 15 Yanmar/
Pramac GBW 22 Yanmar

ELECTRICS:

- Control system via Winetek 7" colour HMI display with Screebee Syncro Ver 3.0 Software
- Built-in Electric Control Cabinet in standard IP 66
- Emergency stop buttons: 3 pcs.
- Start siren: Including
- Led Light: Including 2 units
- Additional external socket for connecting Screenbee PT series Mobile Conveyors Belts
- Additional external socket 230V
- Radio control tracks: Wireless RC system made by Tele Radio /in option

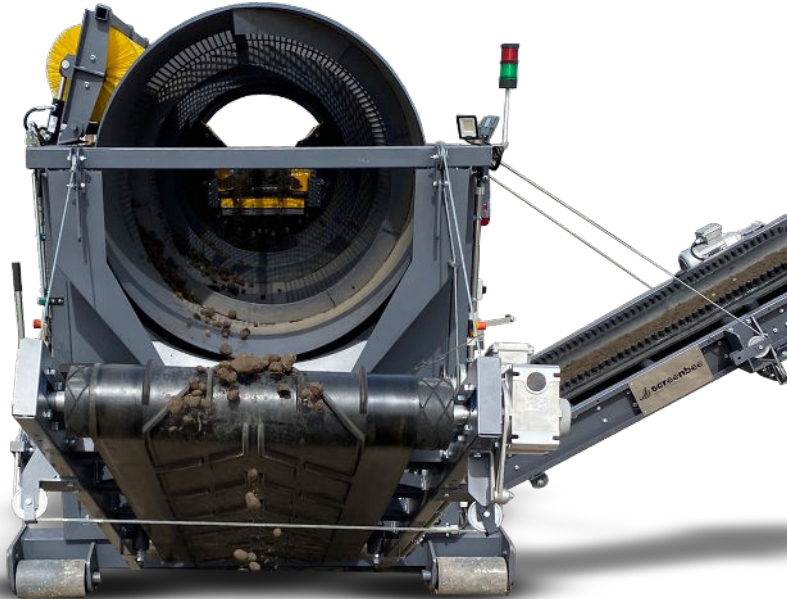

FEED CONVEYOR

- Belt width: 550 mm
- Belt spec: 5-ply 6mm cover Flat or Chevron belt
Drive drum dia: – 190 mm rubbered
- Tail drum dia: 180 mm
- Gearbox: NORD 1.1 KW SK9032

OVERSIZE PRODUCT CONVEYOR

- Stockpile height: 1258 mm
- Belt width: 800mm
- Belt spec: 4-ply 5 mm cover Chevron belt
- Drive drum dia: 190 mm
- Tail drive dia: 80 mm
- Drive system: NORD 1.1 KW SK1Si63BD

FINES PRODUCT CONVEYOR NR 1 (under the drum)

- Belt width: 1000mm
- Belt spec: 4-ply 5 mm cover Flat belt
- Drive drum dia: 190 mm
- Tail drum dia: 180 mm
- Drive system: NORD 1.5 KW SK1Si75 BD

FINES PRODUCT CONVEYOR NR 2 (External side folding)

- Stockpile height: 1590 mm
- Belt width: 800 mm
- Belt spec: 4 -ply 5 mm cover Chevron belt
Drive drum dia: – 190 mm
- Tail drum dia: 180 mm
- Drive system: NORD 1.5 KW SK1Si75 BD

SCREENBEE SB 15.44H

Mobile, compact, hook lift trommel screen

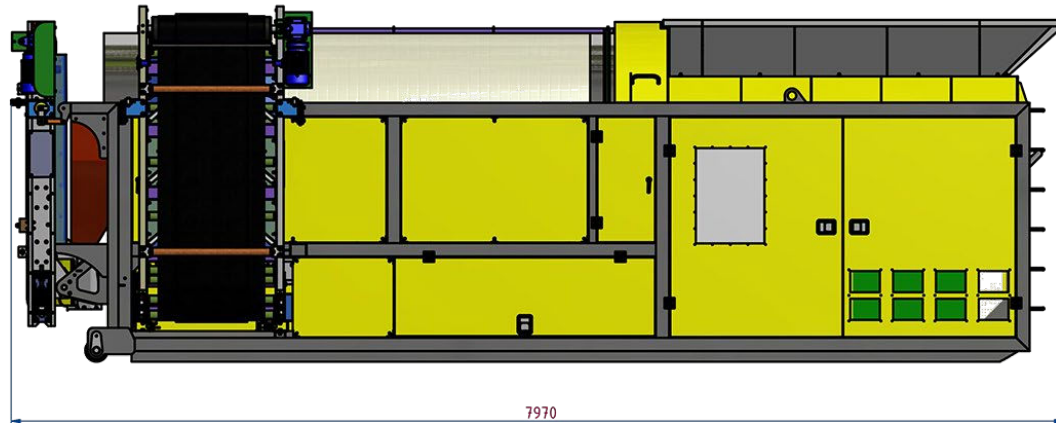
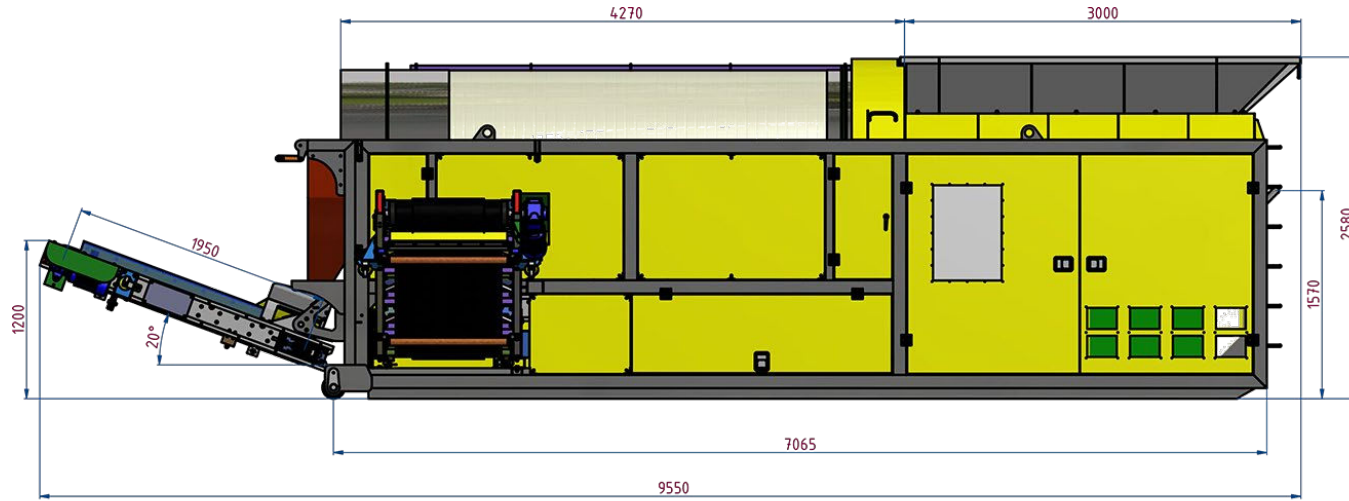

Standard version

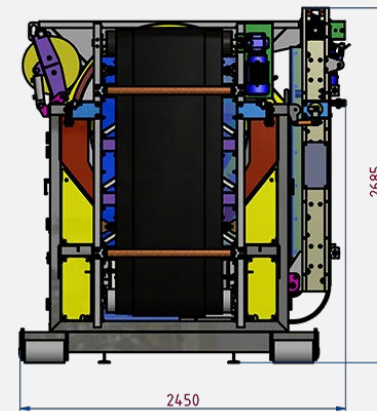
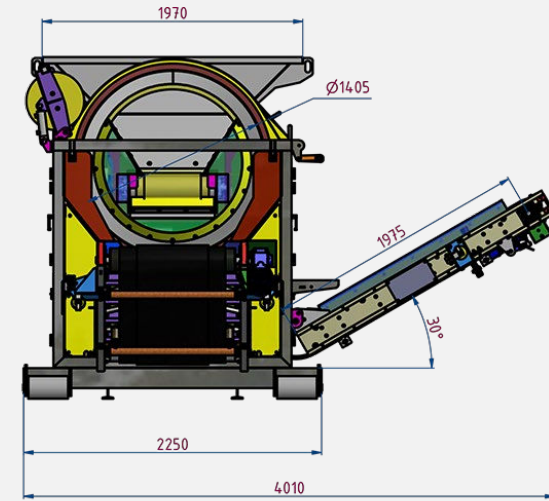

SCREENBEE SB 15.44H Plus

Mobile, compact, hook lift trommel screen

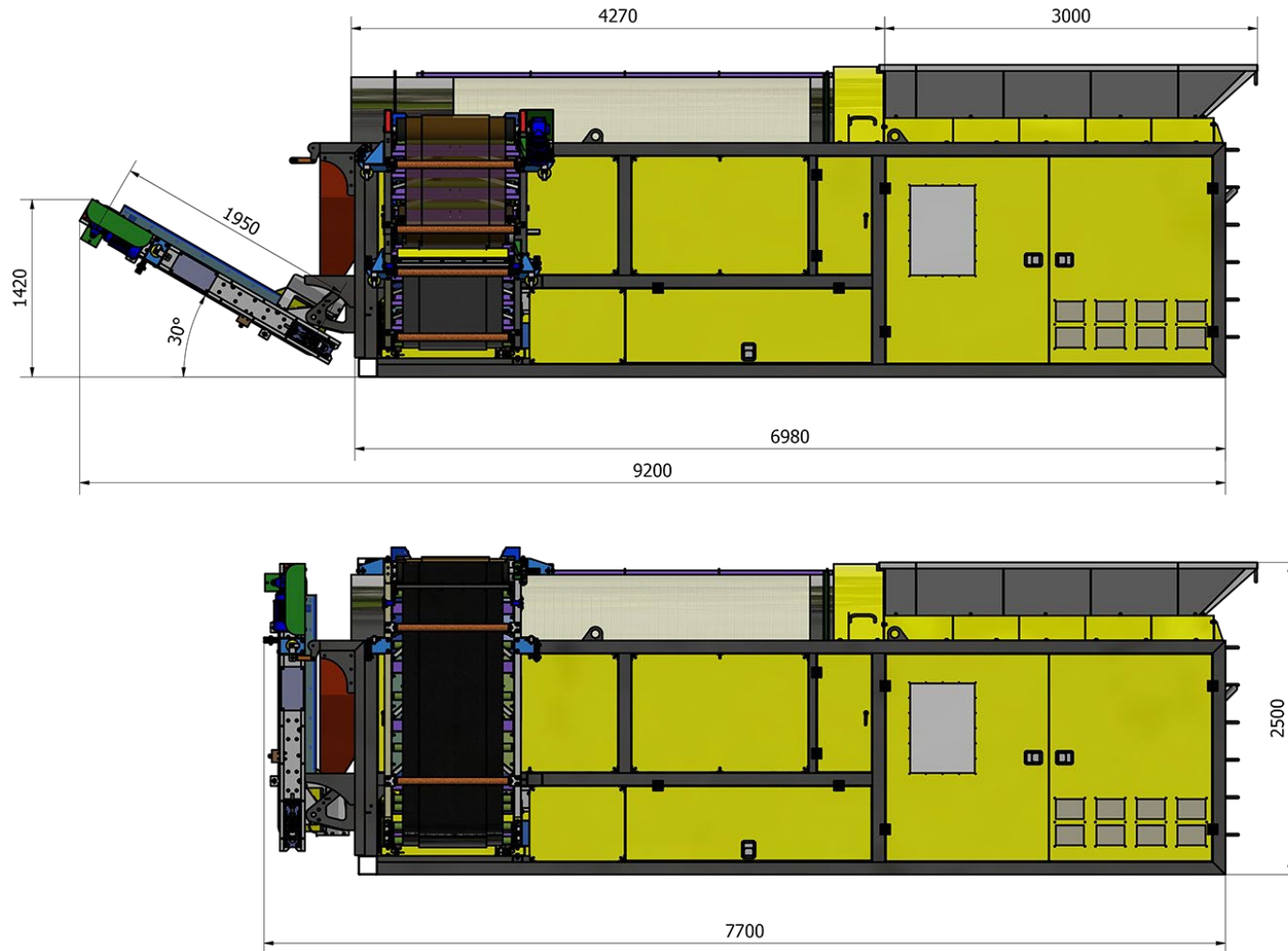

Plus version

Side fine product conveyor is longer and 3-foldable

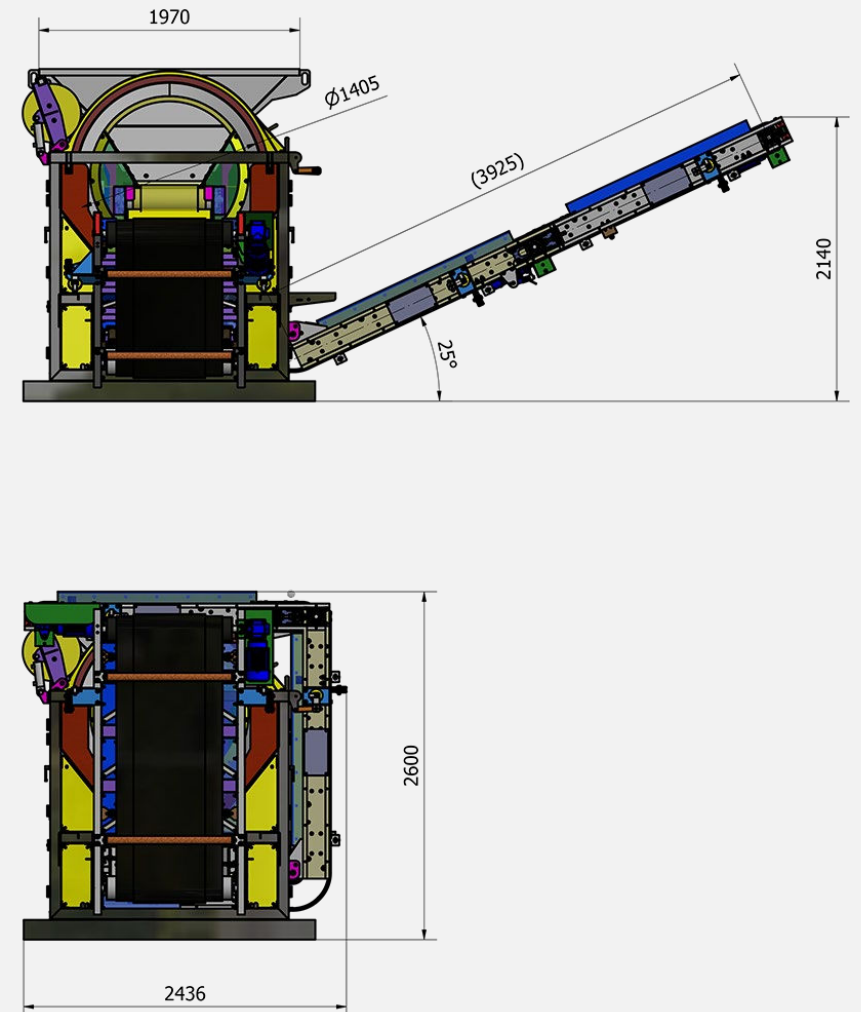

SCREENBEE SB 18.44 S i SB 15.44 S

Our brand new Screenbee SB 18.44 S and Screenbee SB 15.44 S stationary trommel screens feature a modular design and provide unique options for an extension by customers at any time.

The trommel's modular design includes the stationary unit's main frame designed to allow the customer to order additional equipment, just as plug-in components without any structural modifications.



SCREENBEE SB 18.44 S i SB 15.44 S

Hydraulic drum sieve
cleaning brush

Radio control system
*optional

Optional *extension by
additional Screenbee PT
mobile conveyors



Additional conveyor
under the drum sieve for
fine fraction *optional

Additional Magnetic
Pulley including a PT
mobile conveyor for
Fe-non-Fe separation

SCREENBEE SB 18.44 S i SB 15.44 S

The machine can be fed as standard from the power mains via a standard 3x400V 32A 5P power outlet or, if necessary, from an external generator set.

Our stationary trommel screen Screenbee SB 18.43 S, or the smaller Screenbee 15.43 S, can be installed directly on concrete blocks or on its own customised steel bearing structure.

Our stationary trommel screens are available in two versions:

- charge hopper provided with a feeding belt conveyor for the drum sieve integrated with the drum sieve drive, Screenbee Synchro – automatic adjustment of hopper belt speed for optimum screening quality
- vibration feeding hopper including an integrated electric vibrator under the hopper



SCREENBEE SB 18.44 S i SB 15.44 S

MODEL+C22B20A1:C28A1:A1:C20	SCREENBEE SB 18.44 S electric	SCREENBEE 15.44 S electric
Drum sieve size	1900x4300	1500x4300
Machine weight	5500 kg	4200 kg
Sieve drive	NORD4KW	NORD3KW
Feeding conveyor drive	NORD 2.2 KW	NORD 2.2 KW
Number of drum sieve rollers	4 PLUS 4	4 PLUS 4
Hydraulic drum brush	standard	standard
Additional LED lighting	standard	standard
Screenbee Syncro system	standard	standard
TELE RADIO	option	option
Weather shields	option	option
Additional power outlets for		
Screenbee PT conveyors	standard	standard
Length	8200	6900
Height without support system	2700	2700
Width	2400	2000
Charge hopper capacity	5,5 m ³	4 m ³
Feeding conveyor width	1000	800
Conveyor belt	flat or chevron	flat or chevron
Throughput*	up to 200 m ³ /h	up to 140 m ³ /h



SCREENBEE SB15.44T

MOBILE TROMMEL SCREEN

DESCRIPTION:

Mobile, compact Trommel Screen with the following features:

DIMENSIONS AND WEIGHT

- Length (working): 9500 mm
- Width (working): 4000 mm
- Length (transport): 7960 mm
- Width (transport): 2450 mm
- Height (transport): 3100 mm
- Weight: 8700 kg

CAPACITIES

- Diesel tank capacity: 51 L / Genset
- Hydraulic tank capacity: 167 L
- Capacity – Feeder: 3.7 cum

FEED CONVEYOR

- Belt width: 800 mm
- Belt spec: 5-ply 6mm cover Flat or Chevron belt
- Drive drum dia: - 190 mm rubbered
- Tail drum dia: 180 mm
- Gearbox: NORD 1.1 KW SK9032

FINES PRODUCT CONVEYOR NR 1 (under the drum)

- Belt width: 1000 mm
- Belt spec: 4-ply 5 mm cover Flat belt
- Drive drum dia: 190 mm
- Tail drum dia: 180 mm
- Drive system: NORD 1.5 KW SK1Si75 BD

FINES PRODUCT CONVEYOR NR 2 (folding)

- Stockpile height: 2100 mm
- Belt width: 800 mm
- Belt spec: 4 -ply 5mm cover Chevron belt
- Drive drum dia: 190 mm
- Tail drum dia: 180 mm
- Drive system: NORD 1.5 KW SK1Si75 BD



SCREENBEE SB15.44T

MOBILE TROMMEL SCREEN

OVERSIZE PRODUCT CONVEYOR:

- Stockpile height: 1900 mm
- Belt width: 800mm
- Belt spec: 4-ply 5 mm cover Chevron belt
- Drive drum dia: 190 mm
- Tail drive dia: 180 mm
- Drive system: NORD 1.1 KW SK1Si63BD

POWER UNIT AND HYDRAULICS:

- ELECTRIC/HYBRID Power supply
- Genset: Pramac GBW 15 Yanmar/ Pramac GBW 22 Yanmar
- Flywheel Pump: Parker 36 cc
- Total system ow: 186 PM
- Hydraulic tank capacity: 210 L

ELECTRICS:

- Control system via Winetek 9" colour HMI display with Screebee Syncro Ver 3.0 software
- Built-in Electric Control Cabinet in standard IP 66
- Emergency stops: 3 off
- Chassis cabling: Armored cable
- Start siren: Including
- Led Light: Including 2 units
- Additional external socket for connecting Screenbee PT series Mobile Conveyors Belts
- Additional external socket 220 V
- Radio control tracks: Wireless RC system made by Tele Radio
- Pendant track control: Plugged in at the power unit end

SCREEN DRUM:

- Drum size: 1500 mm dia. X 4300 mm
- Drum system: Chain drive via 200 dia. support wheels
- Drive system: NORD 3.0 KW SK9022.1
- Speed adjustable: Including
- Screen Operating Speed Range: 0 to 17 RPM
- Hydraulic Cleaning Brush: Including



SCREENBEE SB18.44M

INCLUDING TRUCK TRAILER

DIMENSIONS AND WEIGHT

- Length (working) 11029 mm
 - Width (working) 4270 mm
 - Length (transport) 9445 mm
 - Width (transport) 2550 mm
 - Height (transport) 3795mm
 - Total weight 10250 kg
- new external folding conveyors

Drum sieve 1400x4300
mesh 16x16 mm
(to be confirmed)

Hybrid/electric
/Built-in aggregate
Pramac GBW 15
Yanmar Diesel

Two folding conveyors
/ hydraulic



SCREENBEE SB18.44M

INCLUDING TRUCK TRAILER



SCREENBEE DMK truck trailer

- Overall length: 8730 mm
- Width: 2410 mm
- Height of load deck: 900 mm
- Length of load deck: 6950 mm
- Rear overhang: 2845 mm
- Wheelbase: 1260 mm
- Axle load: 6000 kg
- Entry weight: 2500 kg
- Permissible payload: 9500 kg

SCREENBEE SB18.44M

INCLUDING TRUCK TRAILER

SCREENBEE DMK truck trailer

- Swing away spindle support on the corners of the trailer: 4 pcs.
- 2 x 7000 kg GIGANT axles, mechanical suspension
- 2 fixed axles
- Wheels with tyres 245/70R15.5 4 pcs.
- Front hitch
- Two-wire brake system by KNORR-Bremse
- Electrical system 24V with trailer couplings
- Wheel chocks 2 pcs.
- Reflective tape
- Container brackets adapted to Screenbee SB 15.44M frame

Notice:

Towing eye ordered separately!

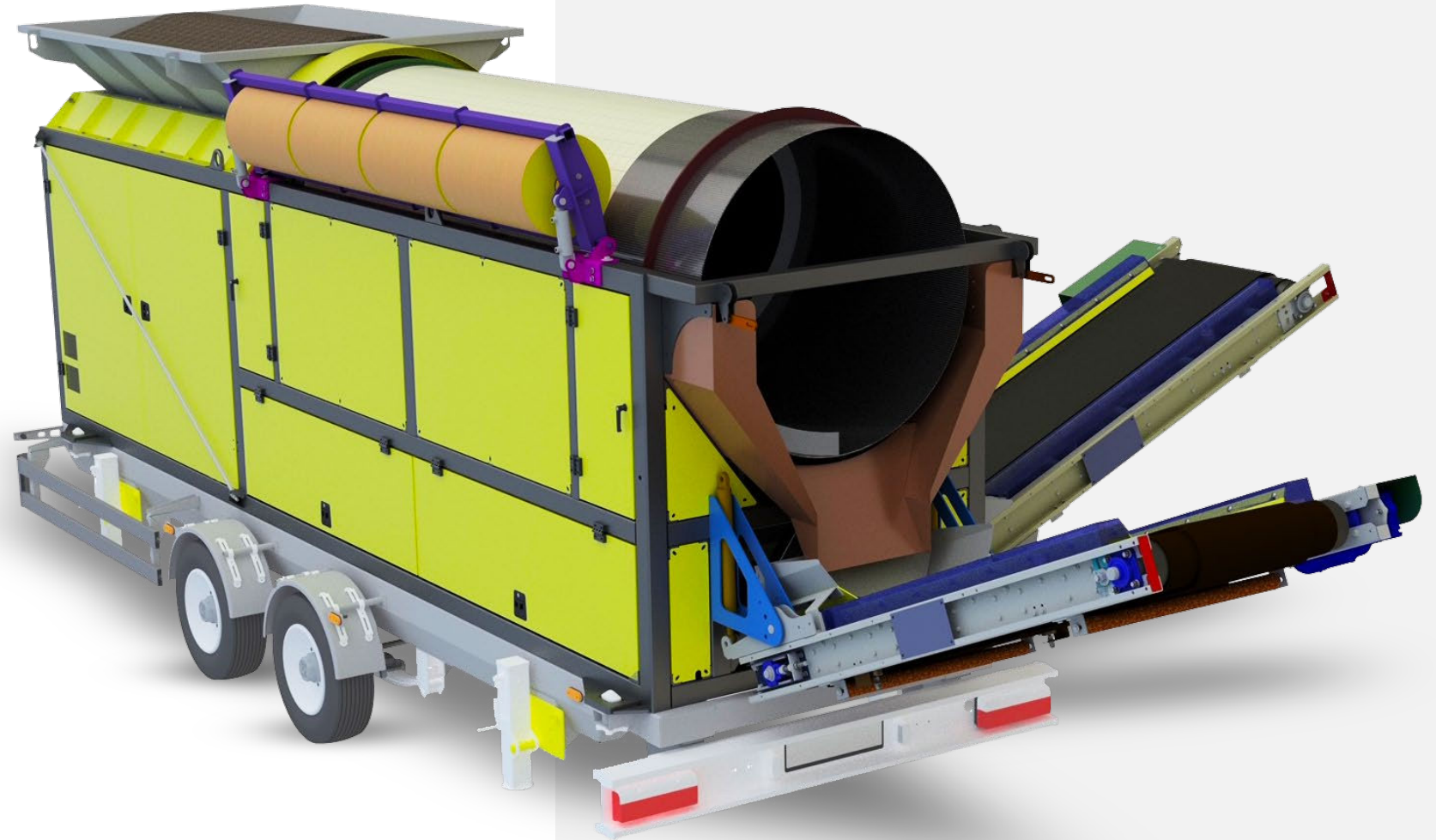

SCREENBEE DRUM SCREENS

We manufacture drum sieves in two versions:

- Steel drum sieves made of black sheets S355 thickness: 6 mm and 8 mm / laser-burnt mesh (10 mm to 100 mm)

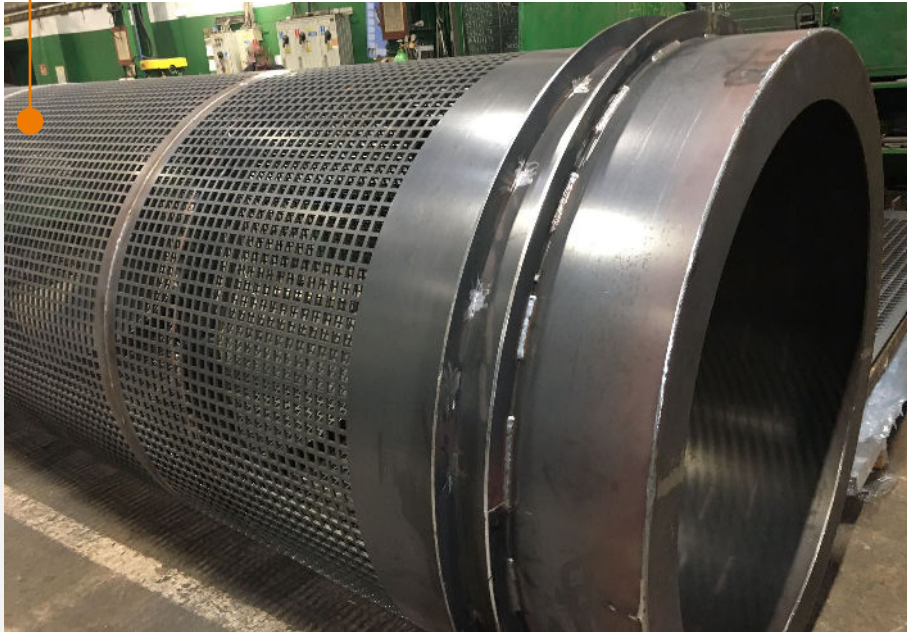

- Drum sieves with replaceable mesh 3 mm to 40 mm

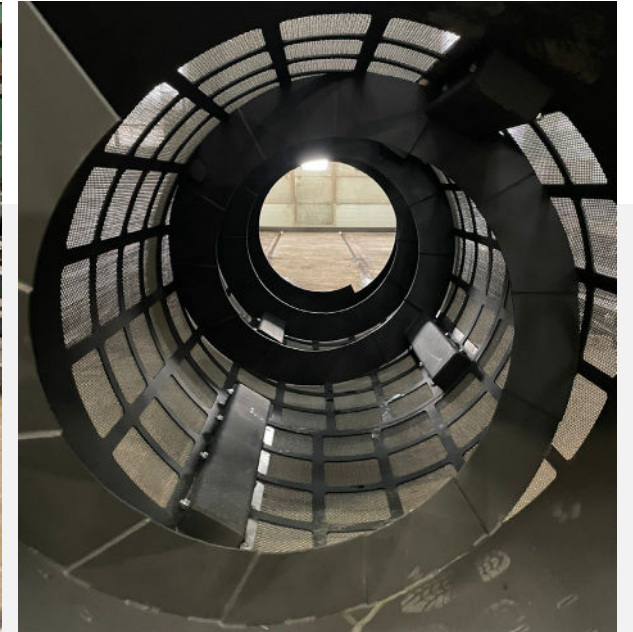

CONVEYORS BELTS PT SERIES

With great pleasure, we present our new Screenbee Engineering product, the Extended Conveyor Belt system PT series. We manufacture conveyors in widths from 600 mm to 1200 mm, also made of stainless steel. All conveyors manufactured by our company have the following technical specifications:

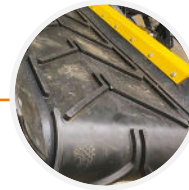

Conveyor belt type flat or chevron 4 -ply. Customized type of belt on request.

Complete electrical installation according to IPP 66 standards

Undercoating in 100% zinc paint. Surface powder coating 100%.

Adjustment of the belt speed, via potentiometer *optional



Safety wire installation on both sides of the conveyors.



CONVEYORS BELTS PT SERIES

Full guarding of the material on the conveyor through fixed side boards protected by band along the entire length of the conveyor



Hook carriers 4 pcs.



Conveyor Belt Tape width:
600/800/1000mm



Nord drives system

Four-stage
height adjustment

Wheel and axle assembly
heavy duty version

APPLICATION OF SCREENBEE



Screenbee trommel screens can be applied for virtually any type of material:

- steel,
- scrap,
- compost,
- topsoil,
- soil,
- sand,
- gravel,
- wood chips,
- construction waste,
- plastic waste,
- mixed waste,
- other.

Our trommel screens have a unique sieve made of high-grade steel resistant to abrasion and damage, with standard dimensions 10x10, 16x16, 25x25 and 40x40 mm.

We can provide a sieve with a customised mesh as well as sieves with a replaceable lining system.



**Let's do business
together!**

SCREENBEE Engineering Sp. z o.o.

📍 ul. Kwiatowa 20A; 55-093 Kielczów

✉ tomasz@screenbee.com.pl

🌐 screenbee.eu

📷 [screenbee_trommel](https://www.instagram.com/screenbee_trommel)

📘 [ScreenBee Engineering](https://www.facebook.com/ScreenBeeEngineering)

Production plant

📍 ul. Towarowa 11 43-190 Mikołów

