



- Swift Change Shafts

- Fully Sealed Oil Bath

- High Material Throughput

### All Star Screening Bucket

### 15-20

**Carrier Weight** 15-20Ton/33000-44000lbs

**Shafts** 6

**Weight** 1320Kg  
2910lbs

**Hydraulic Req.** 120l/min 70-180bar  
31.7gal/min 70-180bar

**Volume** 0.82m<sup>3</sup>  
1.07yd<sup>3</sup>

**Output Capability** 60-70 TPH  
78-91 YdsPH

**Inside Width** 1222mm  
48 inches

**Opening Width** 1576mm  
62 inches

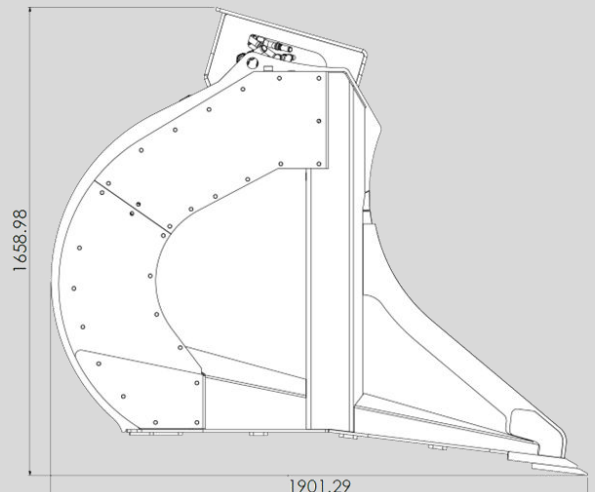
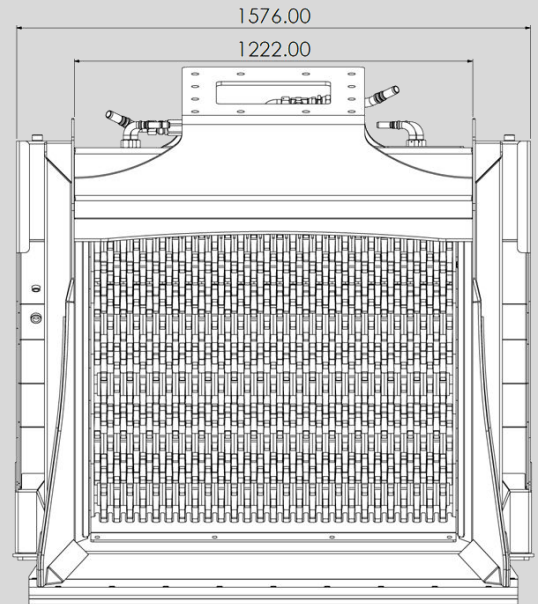

Revolutionising On Site Screening  
**WORLDWIDE**

**LESS = MORE**

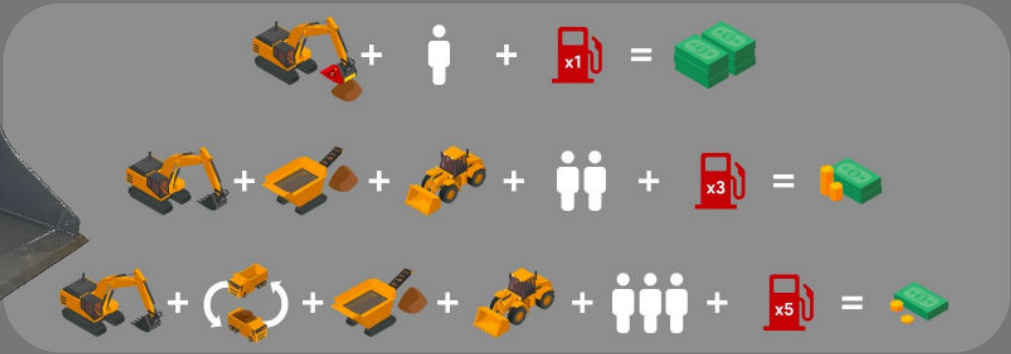

**Less Plant + Less man hours + Less Fuel = MORE PROFIT!**

**One bucket, 6 screening options**

<b>3/8" - 10mm</b> Optional
<ul style="list-style-type: none"> <li>• Soils, Peat, Compost, Bagged Material Etc.</li> <li>• Pipe Bedding and Padding</li> </ul>
<b>1/2" - 15mm</b> Optional
<ul style="list-style-type: none"> <li>• Bagged Top soil    •Top Dressings    •Potting Compost</li> <li>• River Bank Cleaning    •Gypsum</li> </ul>
<b>3/4" - 20mm</b> Standard
<ul style="list-style-type: none"> <li>• Top Soil    •Peat    •Stone Cleaning    •Compost Mixing</li> <li>• Aggregate Sizing    •Biomass Waste    •Furnace Waste</li> </ul>
<b>1-1/4" - 30mm</b> Optional
<ul style="list-style-type: none"> <li>• Wood Chip    •Golf Course Construction</li> <li>• Land Reclamation    •Farm Land Restoration</li> <li>• Vegetable Cleaning</li> </ul>
<b>1-1 /2" - 40mm</b> Optional
<ul style="list-style-type: none"> <li>• Scalping    •Recycling    •Stone Wall Restoration</li> <li>• Large Aggregate Screening    •Plasterboard</li> </ul>
<b>2" - 50mm</b> Optional
<ul style="list-style-type: none"> <li>• Scalping    •Recycling    •Stone Wall Restoration</li> <li>• Large Aggregate Screening    •Land Reclamation</li> </ul>

